

The Clarity™ Margay II is the next generation Margay display for seamless, high definition video walls and banners. Ideal for digital signage and space-constrained control room environments, the Clarity Margay II utilizes DLP® technology with 1920x1080p resolution and BrilliantColor™ for superior HD video performance, impressive vibrant color and high brightness. Unique features like electronic uniformity correction and Set it and Forget it (SiFi™) auto color and brightness balancing ensure optimized video wall brightness and color matching performance and produce an impressive seamless image across a wall of Clarity Margay II's.

The Clarity Margay II is a narrow profile display that is only 18" deep with front and rear serviceability. The modular component design and solid state image alignment make set-up and service quick and easy. The Clarity Margay II also features our industry leading seamless screen design which ensures a rigid flat surface and a bracketing system that minimizes mullions and allows for curved video walls.



FEATURES

High resolution

Full HD (1920 x 1080p)

Industry leading screen technology

Flat, rugged, seamless, high contrast screens

Outstanding video performance

DLP® Technology featuring BrilliantColor™

Quick and easy setup

Solid-state image alignment

Electronic uniformity correction

>90% Brightness Uniformity

Optimized optical performance

SiFi™ auto color and brightness balancing option

Narrow profile & easy serviceability

18" deep with front or rear service

CLARITY MARGAY II: SPECIFICATIONS

Screen diagonal	50"
Resolution	Full HD 1080p (1920 x 1080)
Aspect ratio	16:9
Imaging technology	DLP Smooth Picture™ with BrilliantColor™ Technology
Overscan	+/- 4%
Lamp system	Single Lamp
Lamp wattage	132 watts
Lamp life (median)*	10,000 Hrs
Screen type	Rugged High Contrast
Full viewing angle	180°
Viewing angle (1/5 gain)	H:51°, V:47°
Border (typical)	0
Screen gap (typical)	< 0.7 mm image to image
Brightness	
PrecisionView™-2 Screen (PV2)	400 cd/m² ftL 640 ANSI Lumens
Auto color and brightness balancing	Optional SiFi™ ACB
Brightness uniformity (w/correction)	> 90%
Contrast ratio	1600:1
Power consumption	170 W typical
Operating temperature range	10-35°C
Operating humidity range	20 to 80% non-condensing
Serviceability	Full Front and Rear Access
Colors	16.7 million
Color gamut	> 77% NTSC, 105% EBU
Safety regulations	FCC Class A, EN55022/CISPR22, ICES-003, CNS 13438, EN55024, EN60950, RoHS
Dimensions (in/cm)	
Screen diagonal	50" (127.1 cm)
Width	43.6" (110.8 cm)
Height	32.5" (82.5 cm)
Depth	18.1" (46 cm)
Display weight	91lbs/41.5kg
Maximum stacking**	6
Inputs	
	VGA to FHD (1920x1080 @ 60Hz)
	Analog: D-Sub 15 pin connector with loop through
	Digital: DVI-D with loop through
	Video: SDI, Composite, S-Video, Component-HD (all w/loop through)
Control	WallNet, RS-232, IR remote control

* Lamp manufacturer specification at IEC 61947-1 test conditions.

** Additional rows should consult with Planar. Video walls stacked 3 high or taller should be tied back.

CLARITY MARGAY II: PRODUCT DIMENSIONS



For more information

To learn more about the Clarity Margay II by Planar Systems, call 503-748-1100 or visit www.planarcontrolroom.com.

front

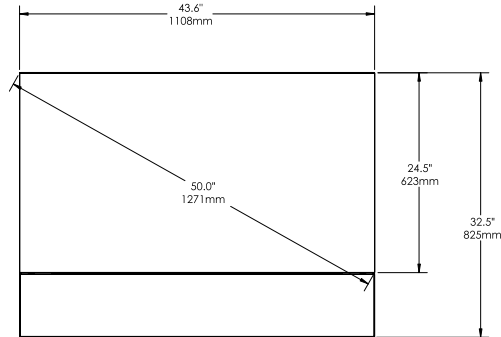

side

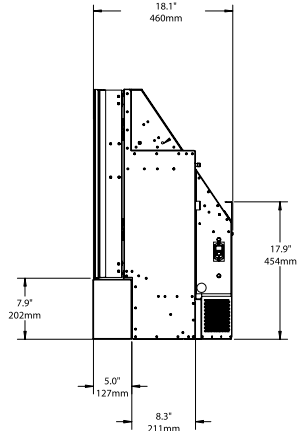

control panel

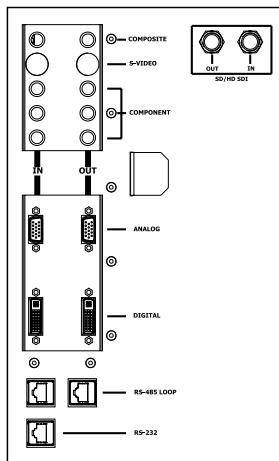

When image experience matters.

Planar Systems, Inc.
 1195 NW Compton Drive
 Beaverton, OR, 97006-1992, USA
 Toll Free +1-866-475-2627
www.planar.com

Planar, Clarity and SiFi are trademarks of Planar Systems, Inc. All other trade and service marks are the property of their holders. DLP, SmoothPicture, BrilliantColor are registered trademarks of Texas Instruments. Copyright © 2010 Planar Systems, Inc. All rights reserved. This document may not be copied in any form without written permission from Planar Systems, Inc. Information in this document is subject to change without notice.

15510 01/10